

# Hanriot Moto-aviette 1923

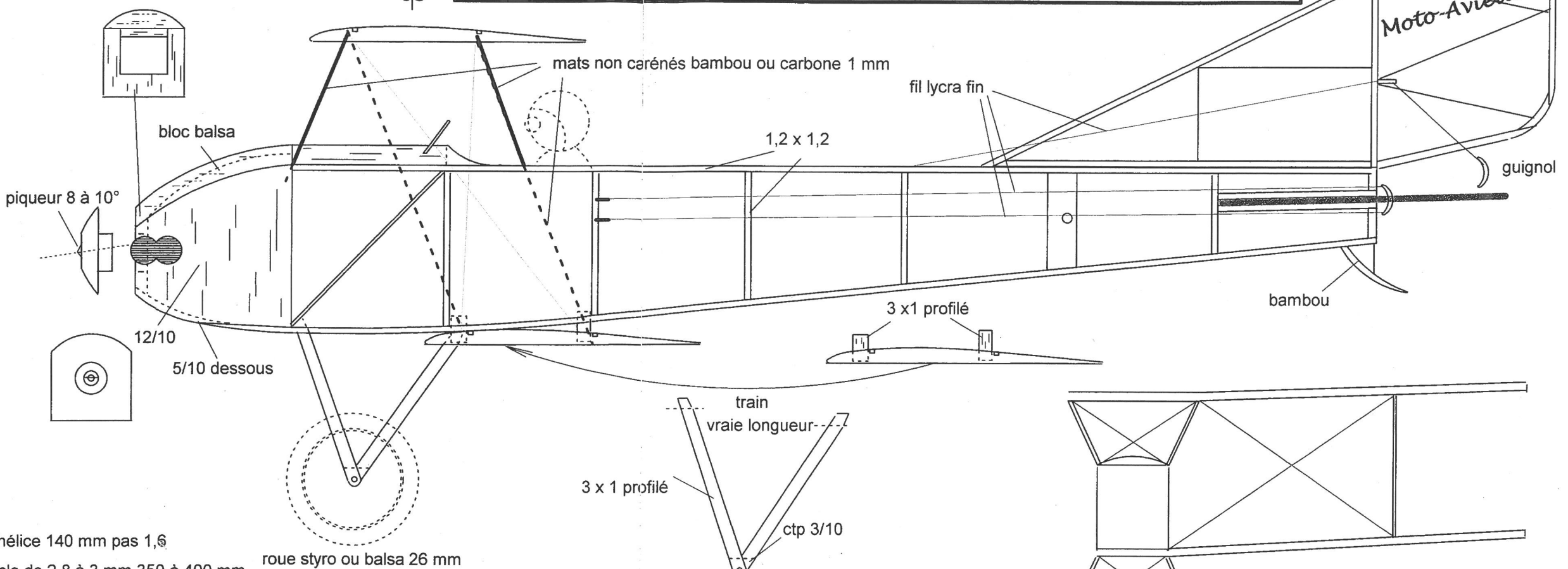

hélice 140 mm pas 1,6  
moteur une boucle de 2,8 à 3 mm 350 à 400 mm  
roue styro ou balsa 26 mm

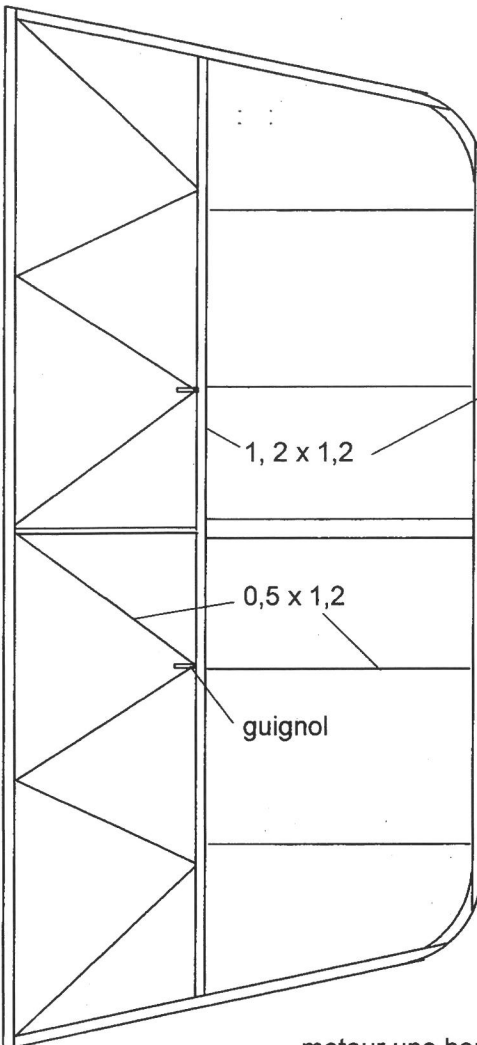
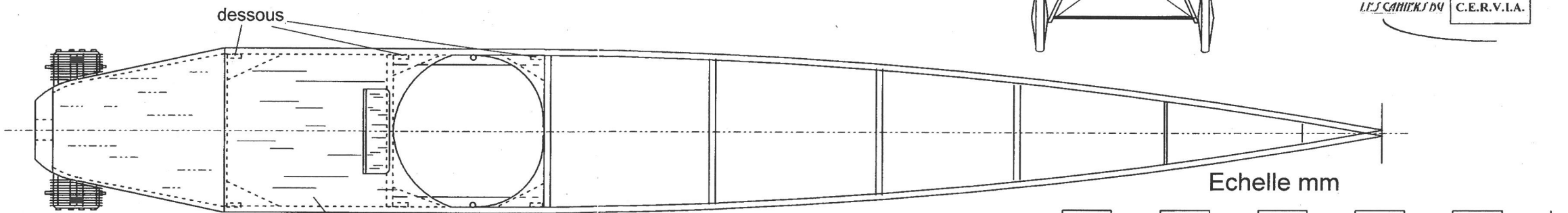

L.F. S. CARRETS BY C.E.R.V.I.A.

dièdre nul possible  
recommandé 10 mm

cale 2 mm au séchage

