

GUSSET  
(TYPICAL,  
WING AND  
STAB)

# FAI PEANUT

BY BILL HANNAN

THANKS TO:  
BOB PECK (PHOTO)  
BILL KRECEK (IDEAS)  
BRUCE HANNAH (ENGINE  
LOAN FOR PHOTOS)

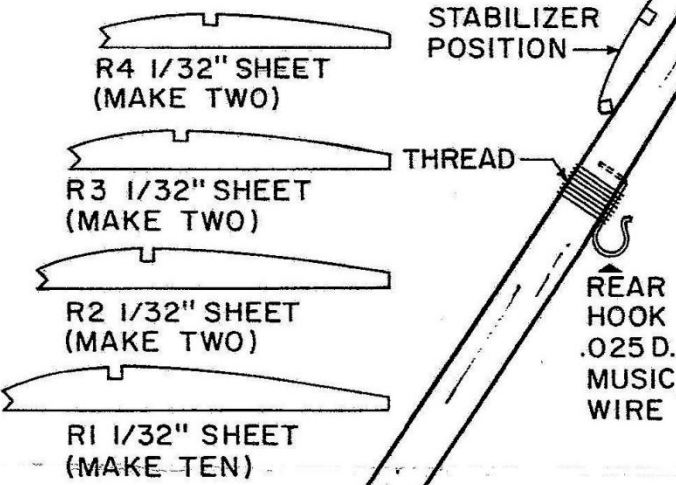
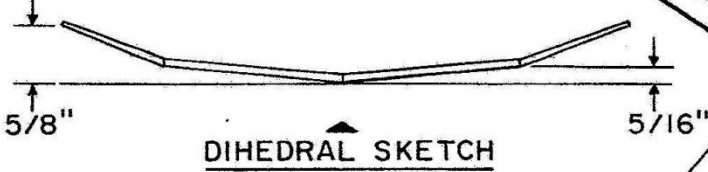

FUSELAGE  
1/4" x 1/8"

STABILIZER

STABILIZER RIB  
1/32" SHEET (MAKE SIX)  
1/16" SHEET (MAKE ONE)

TRIANGULAR  
SIDE PIECE

BALANCE  
POINT

SHAFT  
.032 D.  
MUSIC WIRE

THRUST  
BEARING

WASHERS

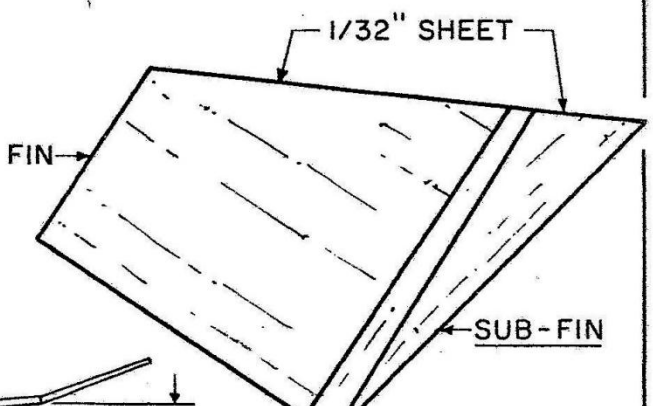

USE 4" D.  
KAYSUN PROP

ALL WOOD  
IS BALSA

STARBOARD WING HALF  
OPPOSITE SHOWN DOTTED

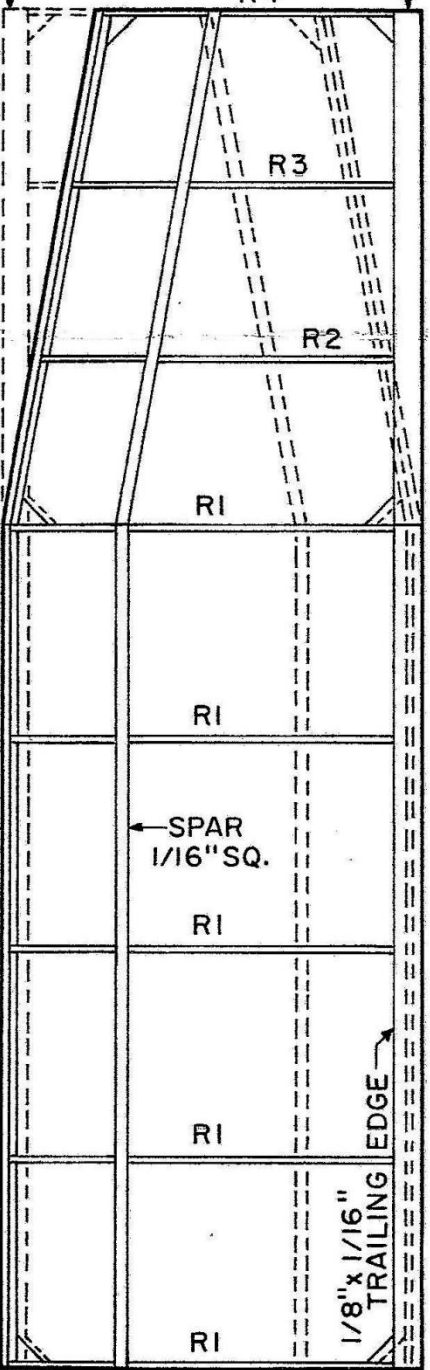

STABILIZER  
POSITION

THREAD

REAR  
HOOK  
.025 D.  
MUSIC WIRE

WING MOUNT  
TRIANGULAR  
SIDE PIECES

DIHEDRAL  
BREAK

LEADING  
EDGE  
1/16" SQ.

FUSELAGE

INTAKE

CRANKCASE

DUMMY ENGINE

x30

PYLON  
3/32"

THRUST  
4° DOWN  
3° LEFT