

Un FID à l'empennage un peu original ! d'après INAV

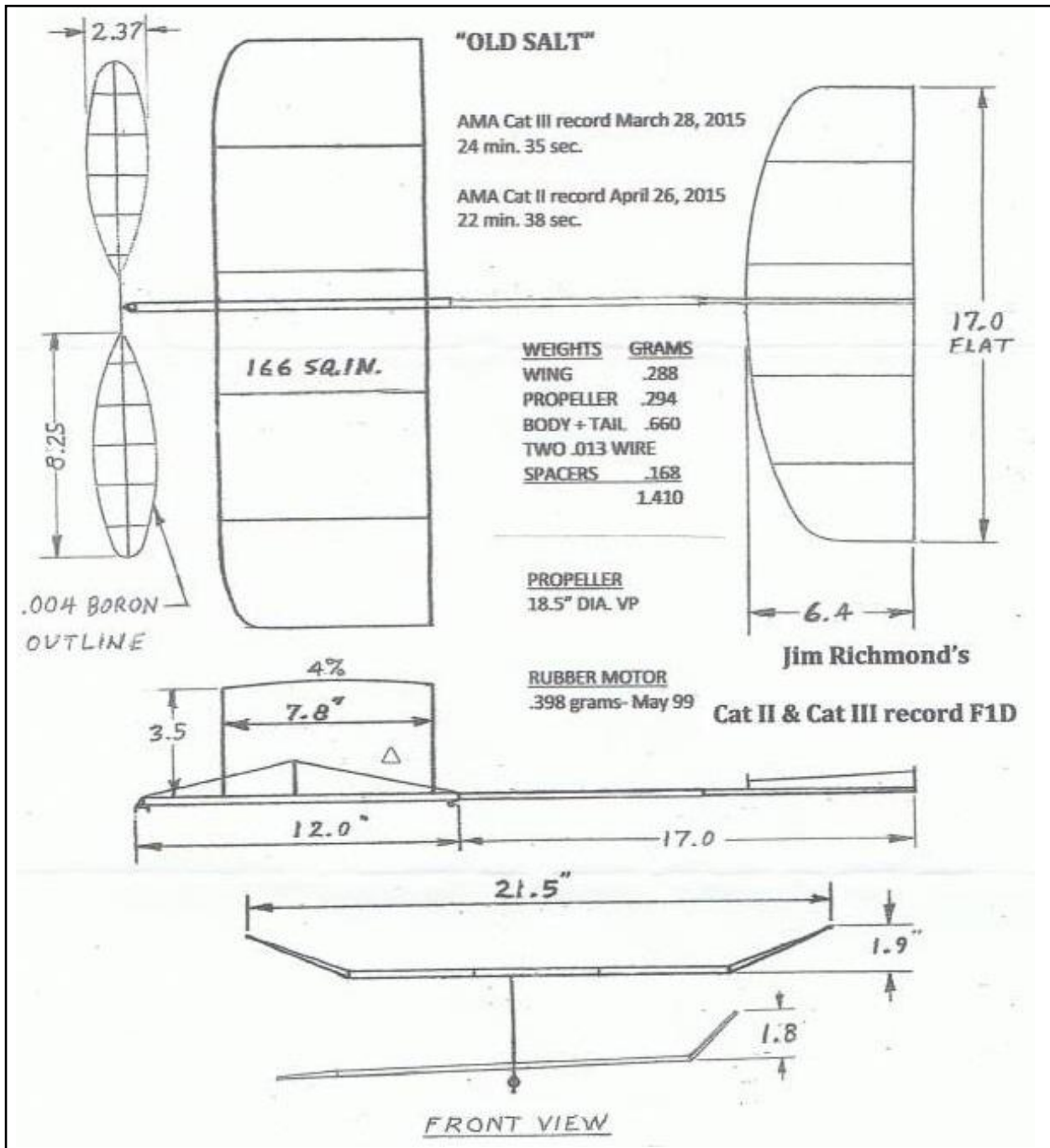

OLD SALT Cat II & Cat III F1D Record holder

Jim Richmond

The plane is a modification of a 15 year old Salty Dog with a shorter length, an 'L' stab, and a VP prop instead of the variable diameter type I had used before. The new shorter .4 gram motor plus the .2 gram extra required plane weight were accommodated by the use of a 2 1/4" .016 wire spacer on each end of the motor.

The Cat III record flight of 24:38 at West Baden, IN was slightly overcooked at first but bumping the girders bled off the power and it ended up over the bar area above some hotel guests where I believe it benefited from some rising warm air and then went dead stick at about 20 feet. A 6.37 inch loop of 5-99 wound to 1100 turns was used. The Cat II record flight of 22:38 was the lucky outcome of a spirited competition with Kang Lee who was only one second shy of the record himself. A 6.7" loop of 5-99 wound to 1200 turns was used.

The L shaped stab probably looks a little strange to some folks but I started using them when I found it was the only way to enable my Easy B to recover from a dive. Otherwise it's lighter and less trouble than making a separate rudder and puts the drag of a dihedral break only on the left side where it can help with the required left turn.